

Clarke®

Division of
ALTO®

**Operator's
Manual**

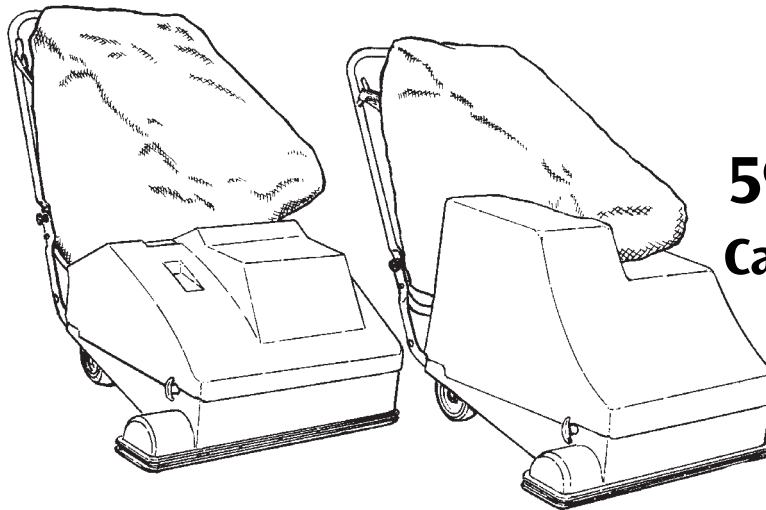

**590 & 590B
Carpet Vacuum**

READ THIS BOOK

This book has important information for the use and safe operation of this machine. Failure to read this book prior to operating or attempting any service or maintenance procedure to your Clarke machine could result in injury to you or to other personnel; damage to the machine or to other property could occur as well. You must have training in the operation of this machine before using it. If your operator(s) cannot read English, have this manual explained fully before attempting to operate this machine.

All directions given in this book are as seen from the operator's position at the rear of the machine.

For new books write to: Clarke®, 2100 Highway 265, Springdale, Arkansas 72764.

Table of Contents

Operator Safety Instructions	3
Machine Specifications	4
Operating Instructions for 24 Volt Battery Charger	5
How To Prepare The Machine For Operation	6
Instructions for Connection To The Power Supply	6
Extension Cords	6
How to Charge The Batteries	7
Controls	8
How To Adjust The Brush	9
How To Operate The Machine	9
Storage Of The Machine	9
Circuit Breaker (590)	9
Maintenance	10
How to Correct Problems In The Machine	11
Main Frame & Brush Assembly Drawing	12
Parts List	13
Housing Impeller & Handle Assembly Drawing	14
Parts List	15
Motor & Drive Assembly Drawing & Parts List	16
Wiring Diagram	17
Electrical Schematic (24 Volts DC)	18

OPERATOR SAFETY INSTRUCTIONS



WARNING



AVERTISSEMENT



ADVERTENCIA



DANGER:

Failure to read and observe all **DANGER** statements could result in severe bodily injury or death. Read and observe all **DANGER** statements found in your Owner's Manual and on your machine.



WARNING:

Failure to read and observe all **WARNING** statements could result in injury to you or to other personnel; property damage could occur as well. Read and observe all **WARNING** statements found in your Owner's Manual and on your machine.



CAUTION:

Failure to read and observe all **CAUTION** statements could result in damage to the machine or to other property. Read and observe all **CAUTION** statements found in our Owner's Manual and on your machine.



DANGER:

Failure to read the Owner's Manual prior to operating or attempting any service or maintenance procedure to your machine could result in injury to you or to other personnel; damage to the machine or to other property could occur as well. You must have training in the operation of this machine before using it. If you or your operator(s) cannot read English, have this manual explained fully before attempting to operate this machine.



DANGER:

Operating a machine that is not completely or fully assembled could result in injury or property damage. Do not operate this machine until it is completely assembled. Inspect the machine carefully before operation. Keep all fasteners tight. Keep adjustments according to specifications.



DANGER:

Machines can cause an explosion when operated near flammable materials and vapors. Do not use this machine with or near fuels, grain dust, solvents, thinners, or other flammable materials.



DANGER:

Using a machine with a damaged power cord could result in an electrocution. Do not use the machine if the power cord is damaged. Do not use the electrical cord to move the machine. To prevent damage to the power cord, do not let the brush touch the power cord when the machine is running. Always lift the power cord over the machine.



DANGER:

Electrocution could occur if maintenance and repairs are performed on a unit that is not disconnected from the power source. Disconnect the power supply before attempting any maintenance or service.



DANGER:

Electrocution or fire could occur if the machine is used on a power circuit that repeatedly trips or is undersized. Have a licensed electrician check the fuse, circuit breaker or power supply, and/or contact your local Clarke distributor for assistance.



WARNING:

Make sure that all labels, warning, cautions and instructions are fastened to the machine. Get new labels and decals from Clarke Industries, Inc., 2100 Highway 265, Springdale, Arkansas 72764.



WARNING:

To prevent electric shock, do not use this machine on wet surfaces. Protect the machine from rain. Keep the machine in a dry building. Always clean the machine with a clean dry cloth.



WARNING:

Do not use this machine as a step or furniture. Injury could occur to the operator.



WARNING:

To prevent electrocution, connect to a properly grounded outlet only (refer to grounding instructions on page 4). Always use a three-wire electrical system connected to the electrical ground.



WARNING:

If the space vac is not working properly, has been damaged, or dropped in water, return it to a service center.



CAUTION:

This machine is not suitable for picking up health endangering dirt.



CAUTION:

This machine is for dry air only and shall not be used or stored outdoors in wet conditions.

INTRODUCTION

For large carpeted areas the 590 and 590B SPACE VAC pays for itself in weeks...with manpower savings. Giant 27 inch swath cleans up to 20,000 sq. ft. of carpet per hour. The labor time for that area would be 400 hours with a standard vac, according to ISSA average figures. The 590/590B Space Vac picks up dirt, sand, grit plus heavy litter such as beverage cups, candy wrappers, soda straws, etc. Designed by Clarke for convention centers, arenas, large reception areas, banquet halls, large stores, long corridors and sports centers. Capacity for the Clarke 590/590B space Vac is designed for longer operating times, without operator fatigue. The Scafitex® bag eliminates dusting with 100% retention of dust particles at 5 microns or less so follow-up dusting is eliminated.

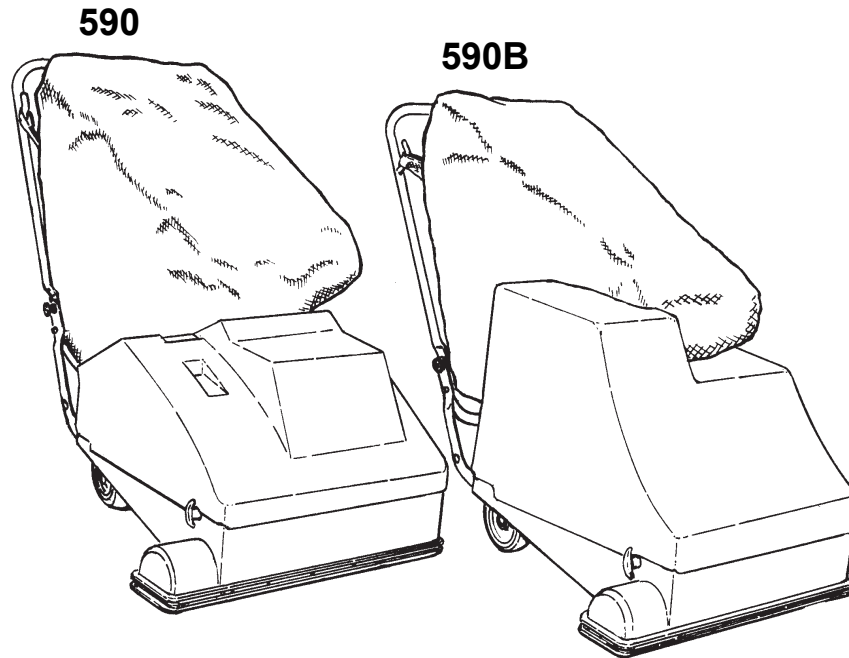







MACHINE SPECIFICATIONS

Code	615421	03042A	03100A
Frequency	60Hz	N/A	N/A
Voltage	120V AC	24VDC	24VDC
Sound	<70 dBA	<70dBA	<70dBA
Vibration	<2.5 m/s/s	<2.5m/s/s	<2.5m/s/s
Model	590	590B	590B
Brush Drive Motor	Continuous Duty	3/4HP 24V/DC	3/4HP 24V/DC
Brush Width	27"	27"	27"
9" impeller (23 cm)	Operated by brush drive motor	Operated by brush drive motor	Operated by brush drive motor
Filter area	16.7 sq. ft.	16.7 sq. ft.	16.7 sq. ft.
Air movement	265 CFM	265 CFM	265 CFM
Height (overall)	38"/27¼" (folded)	38"	38"
Width (overall)	29½"	29½"	29½"
Length (front to back)	48½ x 27¼ (folded)	48½ x 27¼ (folded)	48½ x 27¼ (folded)
Power Cable	73' 3-wire frnd.	N/A	N/A
Weight	130 lbs.	250 lbs.	250 lbs.
Shipping Weight	149 lbs.	300 lbs.	300 lbs.
Battery Charger	N/A	120V 60Hz 40071A	120V 60Hz 40071A

590 Battery Operated Space Vac

Operating Instructions for Clarke 24 Volt Battery Charger

-  **CAUTION:** Connect or disconnect the battery plug only when the charger supply cord is disconnected or arcing and burning may result.
-  **CAUTION:** Do not expose to rain. Replace defective cords immediately. If the charger is dropped or otherwise damaged, inspect it thoroughly.
-  **CAUTION:** Provide adequate ventilation while charging. Improper ventilation could cause fumes or gases to injure the operator or others.
-  **CAUTION:** Never work on the charger with cords connected to the AC supply or to the batteries.
-  **WARNING:** Batteries must be installed and serviced by authorized personnel only. Always wear eye protection and protective clothing when working near batteries. **NO SMOKING!**
-  **WARNING:** Lead acid batteries generate gases which can cause an explosion! Keep sparks and flames away from batteries. Do not put tools or other metal objects across the battery terminals or the top of the batteries.
-  **WARNING:** Because of the positioning of the batteries, you must not use any other maintenance free battery. They may leak. Clarke Part No. 40070A, 12 volt 80 amp hour batteries are specially designed not to leak.
- NOTE:** For best results, charge the batteries after each use.

HOW TO PREPARE THE MACHINE FOR OPERATION

Instructions for Connection To The Power Supply And The Electrical Ground

The machine has a power cord with three conductors and a plug with three terminals. For maximum protection against electric shock, use a circuit that is protected by a ground fault circuit interrupter.

This machine uses a 110 TO 120 volt AC 60 cycle electrical circuit. **Make sure you have the correct voltage and frequency before connecting the power cord to an outlet.** The machine has a plug as shown in Figure A. If a receptacle connected to the electrical ground as shown in Figure A is not available, use an adapter as shown in Figure C. This adapter must be connected as shown in Figure B to an electrical ground in the electrical outlet. Make sure you use the plate screw and the tab to fasten the adapter.

 **WARNING:** To prevent possible electric shock, protect the machine from rain. Keep the machine in a dry building.

 **WARNING:** For maximum protection against electrical shock, use a circuit that is protected by a ground fault circuit interrupter. Consult your electrical contractor.

 **WARNING:** Have worn, cut or damaged cords replaced by an authorized service person.

EXTENSION CORDS

The machine has a power cord with wire size 14 AWG (AWG means American Wire Gauge).

 **WARNING:** If you use an extension cord, use an extension cord with minimum wire size 14 AWG. Do not use an extension cord longer than 50 feet. Do not join two extension cords.

 **WARNING:** Do not move the machine over an electrical cord. Always lift the cord over the machine.

HOW TO CHARGE THE BATTERIES

Put the charger on a flat surface. Make sure the vents on the sides of the charger are at least two inches away from the walls and other objects. Make sure there are no objects near the bottom vents of the charger.

To charge the batteries, follow this procedure:

1. Turn the machine OFF.
2. Connect the DC connector on the charger to the connecting plug on the side of the machine above the circuit breaker.
3. Connect the AC plug on the charger to a receptacle that has the correct voltage and frequency for your charger. Make sure the receptacle is connected to the electrical ground.

NOTE: Read the DC ammeter on the charger. These conditions are normal:

- In the "Start" position, the ammeter dial is in the white area of the meter.
- In the "Finish" position, the ammeter is in the green area of the meter.

If the conditions are not normal, unplug the charger from the wall.

7. The electronic timer stops the charger when the batteries are fully charged.

See the instruction book for the charger, and for more instructions on how to use the charger and charge the batteries.

Handle

The handle on the 590 has a storage and an operating position. To change the position of the handle, use the two knobs on the handle. See figure 1

Note: The 590B Model has a non-folding handle.

To put the handle in the storage position, pull out the two knobs. Rotate the knobs $\frac{1}{4}$ turn. Put the handle forward in the storage position.

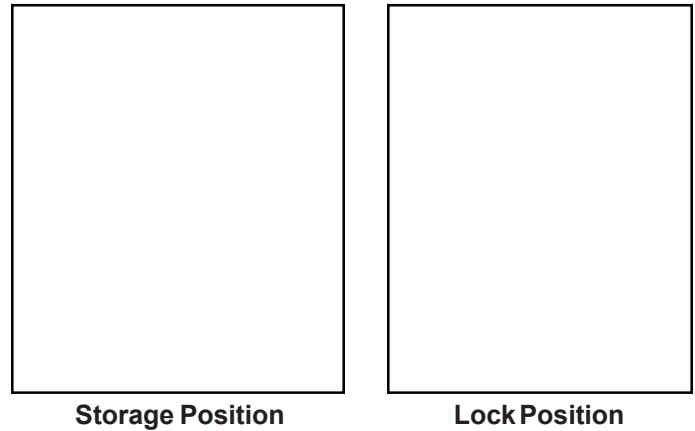

Figure 1

To put the handle in the operating position rotate the knobs to the lock position. Put the handle in the operating position.

FILTERBAG

Make sure the filter bag is empty and clean before you install the bag and begin to use the machine. Use the zipper (1) on the bag to remove the contents of the bag. See figure 2.

To install the filter bag, put the opening (2) in the bag around the lip (3) that holds the bag. Tighten the strap (4) to hold the bag in position. See figure 2

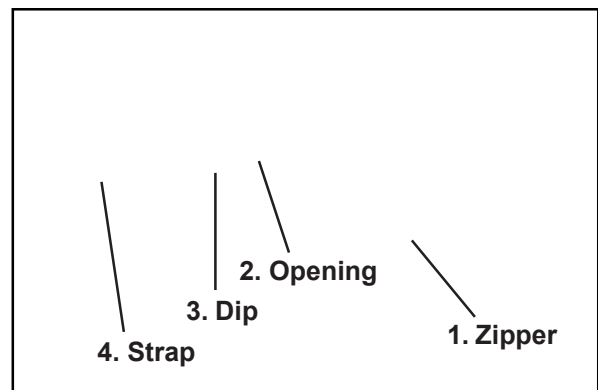

Figure 2

HOW TO ADJUST THE BRUSH

The brush height adjustment has four settings. To adjust the setting, pull out the handle on the right-hand side of the front of the machine. Move the handle to the correct setting for your carpet. The setting is correct when the brush sweeps the surface of the carpet. The setting is too low when the brush wipes the carpet. See figures 3 and 4

For very low pile carpet, and for hard surface floors, put the adjustment lever in the farthest forward position.

HOW TO OPERATE THE MACHINE

Use the Models 590/590B Space Vac only on large areas of floor. Move the machine steadily forward and backward in short movements.

To clean near the wall, put the guide wheel on the right-hand side of the machine against the wall.

Stop when the performance of the machine decreases.

SERVICE

The following should be done by the operator when servicing the machine:

Keep the machine clean. It will have longer life and need fewer repairs.

For the best performance, remove the contents of the filter bag each time you finish using the machine. **Sweep the inner surface of the bag for the best filter efficiency.**

STORAGE OF THE MACHINE

Before you put the machine in storage, clean the machine and the filter bag. Put the power cord around the top of the handle. To put the handle in the storage position, pull out the two knobs on the handle. Rotate the knobs $\frac{1}{4}$ turn. Put the handle forward into the storage position. Keep the machine in a storage area in a building.

CIRCUIT BREAKER

The electrical circuit in the Model 590 is protected by a circuit breaker. If the circuit breaker opens, wait approximately 10 minutes for the machine to cool. Press the red button on the right-hand side of the machine to reset the circuit breaker. See figure 5. You can feel the circuit breaker lock into the closed position.

Check the vacuum system and the brush for obstructions. Check the settings of the brush. Obstructions or an incorrect brush setting can make the motor too hot.

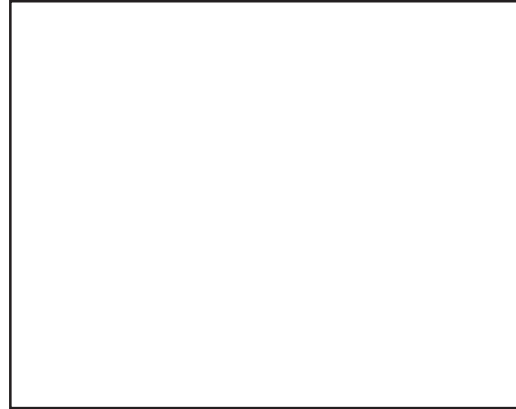

Brush Height Adjustment - Figure 3



WRONG

CORRECT

Figure 4



Figure 5

MAINTENANCE

WARNING: To prevent electric shock, always remove the electrical plug from the electrical outlet before doing any repairs or maintenance to this machine.

WARNING: Maintenance procedures must be done only by persons authorized to do maintenance.

NOTE: For safe operation, and longer life of your Clarke product, use only Clarke replacement parts.

How To Adjust The Belts

The belt to drive the brush: The tension of this belt is controlled by a spring. If necessary, replace the spring and the belt. See figure 6

The belt to drive the vacuum impeller: The tension of this belt is controlled by the position of the motor. To get access, remove the main cover of the machine. Loosen the four hex screws that fasten the motor, and move the motor forward or backward. Tighten the four hex head screws forward or backward. Tighten the four head screws and install the cover of the machine. See figure 7.

How To Get More Use From The Brushes

When the brush becomes worn, rotate the brush shaft to get more use. When the brushes becomes worn more, replace the two halves of the brush.

To rotate the brush shaft, follow this procedure:(See figure 6)

1. Remove the electrical plug from the outlet.
2. Put the machine upside down.
3. Remove the side shoe (3) from the left-handed end of the brush shaft.
4. Loosen the retainer (4) and the spacer (5) on the end of the brush shaft.
5. Rotate the brush shaft $\frac{1}{2}$ (180°) turn.
6. Tighten the retainer (4).
7. Install the side shoe.

To change the two halves of the brush, remove the screws (6). Replace the brush section and the screws. See figure 6

Electrical

WARNING: Electrical repairs must be made by authorized personnel only.

MOTOR AND CIRCUIT

The Model 590 has a capacitor start, induction run motor.

The Model 590B has a permanent magnet motor. This motor has carbon brushes. The brushes and commutator should be inspected annually for damage and/or wear.

This motor needs no maintenance. If damage occurs to the motor, return the machine to a Clarke authorized repair location. If damage occurs to the electrical circuit, make sure the machine is repaired by an authorized person. The machine must be tested for electrical safety before it is used again.

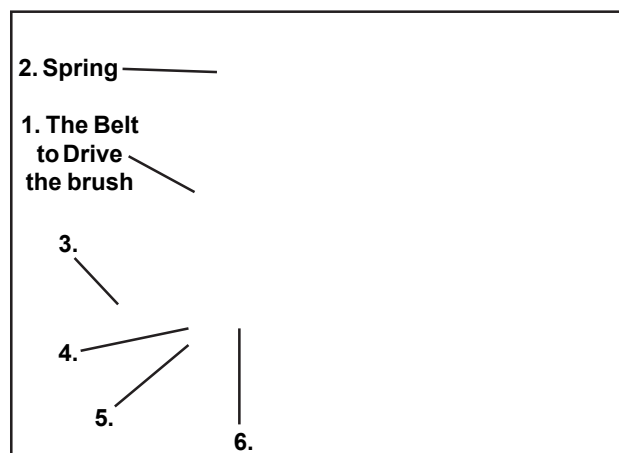

Figure 6



Figure 7

HOW TO CORRECT PROBLEMS IN THE MACHINE

Problem	Cause	Action
The machine does not run.	There is no power.	There is an obstruction. See "Circuit Breaker" in the manual. The electrical outlet, power cord, electrical switches and motor brushes are to be checked. Electrical inspections must be made by a person authorized to do maintenance. Electrical repairs must be made by a person authorized to make electrical repairs.
		Also check for proper battery voltage on the 590B.
The machine does not remove debris from the floor.	The filter bag is dirty.	If the bag is 1/3 full, clean the cloth bag and turn it inside out. If the machine is used to pick up heavy debris, clean the bag before it is 1/3 full.
	The brush does not turn clockwise when seen from the right-hand side of the machine.	Return the machine to a Clarke Service Branch or a Clarke authorized Service Center to have the motor wired correctly.
	The brush setting is not correct.	Change the brush setting. If the brush is set too low on a deep pile carpet, the housing can stop the air flow.
	The brush is worn.	Replace the ¾" brush.
If the bag does not inflate.	The fan belt is slipping or broken.	Adjust the fan belt or replace.
The brush does not rotate.	There is an obstruction in the bearings on the end of the brush.	Remove the obstruction.
	The belt is broken or loose.	Replace or tighten the belt.
	There is low line voltage.	Remove other appliance on the line or provide a separate circuit.
	The brush drive motor will not run.	Push the circuit breaker button. Check the battery voltage on the 590B.

Clarke®
Model 590/590B
Main Frame & Brush Assembly 4/01

WARNING: (Ref #97)
Because of the positioning of the
batterless, you must not use any
other maintenance free battery.
They may leak. Clarke P.N.
40070A volt batteries are specially
designed not to leak.

24



Clarke®
Model 590 & 590B
Main Frame & Brush Assembly 4/01

Ref. No.	Part No.	Description	QTY
1	909007	Cord Assembly 75'	1
	40025A	Cord 230V	1
2	627561	Strain Relief	1
3	611101	Bushing, Motor	2
4	962835	Screw #10-24 x 1/2	13
5	610820	Bracket, Switch Mounting	1
6	47394A	Switch	1
7	812180	Clip, Nylon	2
8	980603	Washer #1110	1
9	911594	Clip, Terminal	1
10	899254	Tie, Nylon, Wire	2
11	691101	Bushing, Snap	1
12	962109	Screw, 10-24 x 5/8	2
13	NI*	Plate, Model & Serial No.	1
14	930082	Rivet, 1/8 x .310 Pop	2
15	215108	Label, Manufacture Date	1
16	805160	Label, Inspection	1
17	618522	Stop, Knob	1
18	613920	Handle, T-Knob	1
19	925554	Pin, .093 Dia. x .62 Roll	1
20	615125	Label, Brush Adjustment	1
21	617522	Roller, Asm. Side	1
22	930122	Rivet, 1/8 Dia. Pop	2
23	962727	Screw 8-32 x 1/2 Pan	7
24	77094A	Label, Ground Symbol	1
25	611221	Bumper	1
26	677211	Retainer, Bumper Strip	16
27	962900	Screw, 10-16 x 5/8	12
28	920349	Nut, 1/4-20	1
29	912362	Breaker, Circuit (120 Volt)	1
	912363	Breaker, Circuit (220 Volt)	1
	41416A	Breaker, Circuit 45 A (590B)	1
30	912364	Lead Asm., Motor/Circuit	1
31	952470	Wire Asm., SW/Circuit	1
32	920200	Nut, 10-24 Hex	2
33	618122	Sleeving, Leads	2
34	612324	Cover, Circuit Breaker	1
35	617423	Rod, Adjusting	1
36	615120	Lever Asm., Adjusting	1
37	618221	Spacer, Adjusting Lever	1
38	616720	Pin, Clevis	2
39	612420	Cable Asm., Adjusting	1
40	618320	Spring, Compression	1
41	980651	Washer	7
42	925036	Pin, Dia. 3/32 x 3/4	2
43	980646	Washer 9/32 x 5/8 x 1/16	1
44	962455	Screw 1/4-20 x 1	1
45	902734	Bearing, Nylon	1
46	618322	Spring, Wave	1
47	613605	Guard, Thread	1
48	902619	Bearing	2
49	610206	Adapter, Brush	1
50	617720	Shaft, Brush	1
51	610921	Brush, Half, Chevron	2
52	962821	Screw, 8-00 x 5/8	12
53	617920	Shoe, Rear	1
54	616908	Pulley, Brush, Drive	1

Ref. No.	Part No.	Description	QTY.
55	613601	Guard, Brush, Thread	1
56	618222	Spacer, Brush Adjustment	1
57	617206	Retainer	1
58	962968	Screw, 10-24 x 1/2 Pan	2
59	617921	Shoe, Front	1
60	617923	Shoe, Side	1
61	962992	Screw 8-32 x 3/8	2
62	920160	Nut 5/16-18	2
63	980982	Washer, Flat	2
64	619002	Tube, Brush	1
65	882156	Clip	1
66	628384	Spring, Latch	1
67	617726	Shaft, Adjustment	1
68	925004	Pin, 1/16 x 1/2	2
69	67901A	Spring, Idler Tension	1
70			
71	610322	Arm As., Idler	1
72	748250	Spacer, Idler, Arm	2
73	962158	Screw, 5/16-18 x 7/8	1
74	616920	Pulley, Idler	1
75	757360	Ring, Snap	1
76	902648	Bearing	2
77	613222	Frame, Asm., Main	1
78	980613	Washer, Wave	1
79	962395	Screw, 5/16-18 x 1 3/4	1
80	612722	Caster, Asm., Front	2
81	920196	Nut, 1/2-13	2
82	617725	Shaft, Caster	2
83			
84	85811A	Screw, 18 x 3/4	8
85	52109A	Caster, Rigid 6.0 x 1.5	2
86	611220	Bumper	1
87	980652	Washer, 5/16 x 9/16 x 1/16	8
88	612101	Clip	7
89	925044	Pin, Cotter	2
90	613622	Guard	1
91	613620	Guard	1
92	613621	Guard, Pulley	1
93	613623	Guard, Belt	1
94	920108	Nut, 6-32 Hx	2
95	49675A	Harness, Wire, Switch	1
96	61232A	Bracket, Battery, Top Pntd.	1
97	40703A**	Battery, 12 Volt to Serial# XE	2
	40070A**	Battery 12V GEL 90AH Beginning w/Serial # XE	2
98	41213A	Cable, Series, Neg.	1
99	962813	Screw 5/16-18 x 2 Ft.	3
100	61233A	Bracket, Battery, Bottom Pntd.	1
101	67860A	Spacer, Battery, Bracket Pntd.	3
102	49677A	Harness, Wire Charger (590B)	1
103	962980	Screw, 6-32 x 1 Pn St	2
104	49674A	Harness, Wire, Circuit Breaker	1
105	962983	Screw, 1/2-20 x 5/8	2
106	920342	Nut 3/8 Nylon	4
107	67127A	Rod, Battery	2
108	41212A	Cable, Battery Pos.	1
109	878561	Solenoid, 24 Volt	1
110	920112	Nut, 6 x 32	2
NI*	47609A	Terminal, Lug 5/16	1
NI*	85809A	Screw, 5/16-1/2	4
NI*	110854	Nut, 5/16	4

NOTE: ** 40703A use 40510A or 40511A Wet Battery Charger or equal

NOTE: ** 40070A use 40071A or 40072A Wet Battery Charger or equal

Note: *Not Illustrated

Clarke®
Model 590/590B
Housing Impeller & Handle Assembly Drawing
11/02

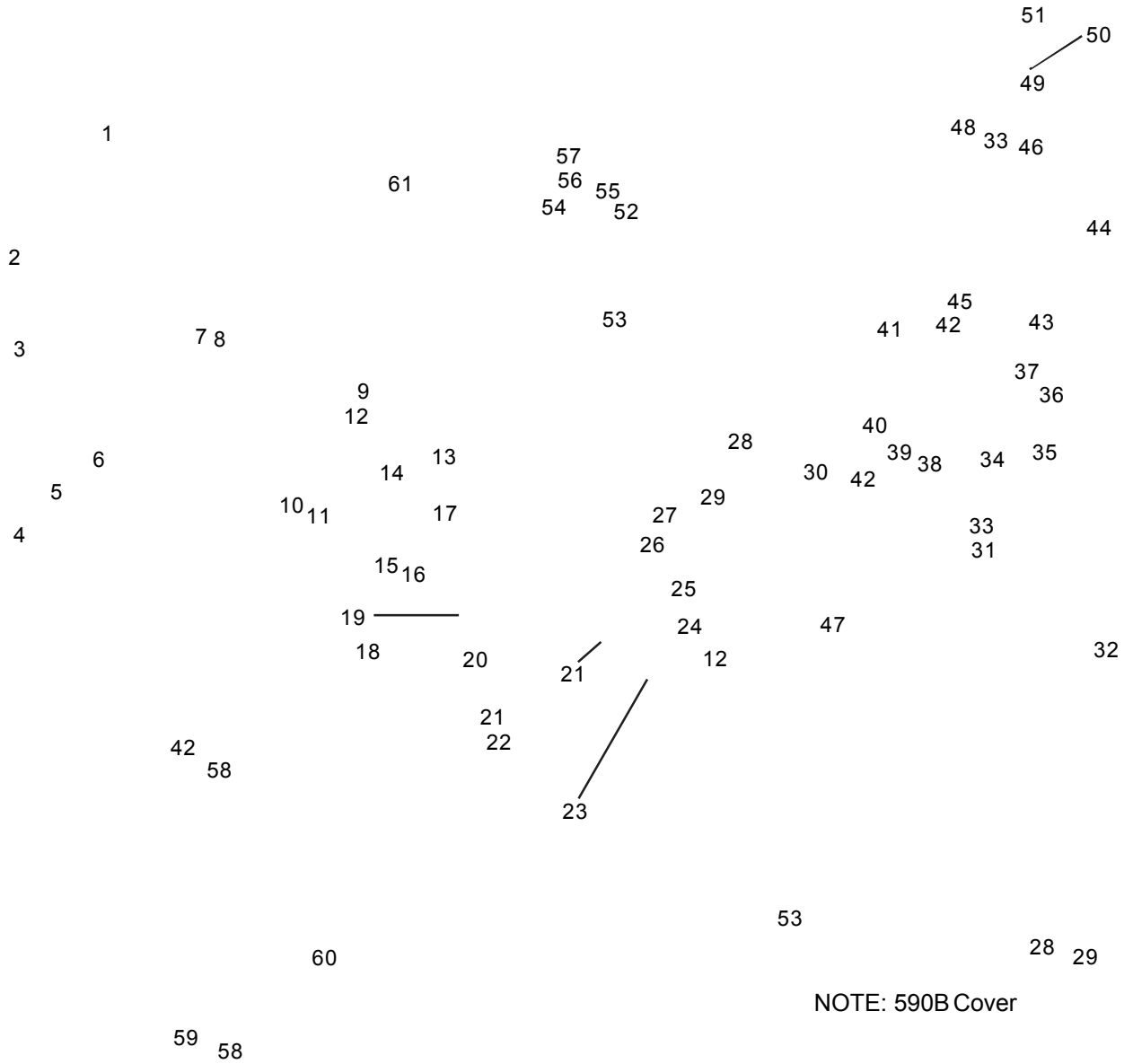

NOTE: 590B Handle

NOTE: 590B Cover

Clarke®
Model 590/590B
Housing Impeller & Handle Assembly
Parts List 11/02

Ref #	Part No.	Description	Qty
1	612720	Deflector	1
2	84808A	Screw 10-24 x ¾	4
3	66621A	Plate, Adapter	1
4	619221	Cable, Tie	2
5	612422	Coupling, Air Duct	1
6	60068A	Housing, Impeller	1
7	920208	Nut ¼-20 Hx	3
8	980657	Washer ¼ Lock	3
9	962446	Screw, ¼-20 x 1"	3
10	920110	Nut 5/16-18	1
11	980210	Washer, Impeller	1
12	915044	Key 3/16 x 3/16 x 1"	2
13	614820	Impeller	1
14	618220	Spacer, Impeller	1
15	067304	Ring, Retainer	1
16	902550	Bearing	2
17	617704	Shaft, Impeller	1
18	613220	Frame, Main	1
19	613421	Gasket, Impeller, Cover	1
20	612327	Cover Asm., Impeller	1
21	980652	Washer 5/16 Lock	4
22	85811A	Screw 5/16-18 x ¾ Hex	4
23	616902	Pulley, Motor	1
24	962184	Screw ¼-20 x 3/8	2
25	962901	Screw 9/32 x ¾ Hex HiLo	6
26	618525	Support, Housing	1
27	60069A	Cover, Main	1
28	980257	Washer	4
29	962546	Screw 10-24 x 5/8	4

Ref #	Part No.	Description	Qty
30	64473A	Handle, Lower Half, w/Brace	1
31	85376A	Screw ¼-20 x 5/8 (590B only)	4
32	30026A	Cover, Main (590B only)	1
33	83002A	Rivet ¼ Dia. x .490	8
34	960357	Screw, Shoulder	2
35	615001	Knob, Handle Release	2
36	980603	Washer, 5/16 Plain	2
37	920280	Nut, 5/8-18 x 3/8 Hex Jam	2
38	617202	Retainer	2
39	618301	Spring, Handle, Release	2
40	617001	Plunger, Handle Release	2
41	925530	Pin, 3/32 x 1/2	2
42	920349	Nut ¼-20 ESNA Stop	10
43	64474A	Handle	1
44	610620	Bag, Filter	1
45	618508	Strap	1
46	614520	Hook, Cord, Storage	2
47	47365A	Switch, Power (590B only)	1
48	962731	Screw 8 x 1/2 Pn Type A	1
49	980621	Washer #1108	1
50	627562	Strain, Relief	1
51	812180	Clamp, Wire	1
52	615131	Label, Warning	1
53	70673A	Label, Clarke	1
54	446303	Plate, Fire, Warning	1
55	930074	Rivet, 1/8 Closed End	2
56	613420	Gasket, Plate	1
57	616420	Plate, Switch	1
58	980413	Washer, Flat ¼	4
59	67864B	Spacer	2
60	962455	Screw ¼-20	2
61	70651A	Label, Div. of ALTO	1
NI	46730A	Static Strap (Battery Model)	1

Clarke®
Model 590/590B
Motor & Drive Assembly
Drawing & Parts List 12/98

Ref #	Part No.	Description	Qty
1	962835	Screw 10-24 x ½ Hex	1
2	954010	Wire, Assembly #16 Green	1
3	980603	Washer #1110	1
4	611101	Bushing, Motor	1
5	615221	Motor, Drive (120 Volt)	1
	615227	Motor, Drive (230 Volt)	1
6	55410A	Key ³ / ₁₆ X 2½	1
7	920256	Nut ⁵ / ₁₆ -18 Hex	4
8	980652	Washer .319 x .586 x .078	4
9	980651	Washer ¹¹ / ₃₂ X ¹¹ / ₁₆ X ¹ / ₁₆	4
10	962184	Screw ¼-20 x ³ / ₈	6

Ref #	Part No.	Description	Qty
11	903768	Belt, Fan	1
12	616901	Pulley, Motor, Impeller (120V)	1
	616906	Pulley, Motor, Impeller (230V)	1
13	616904	Pulley, Motor, Brush (120V)	1
	616905	Pulley, Motor, Brush (230V)	1
14	903769	Belt, Brush, Drive	1
15	962985	Screw ⁵ / ₁₆ -18m x 1¼ Hex	1
16	47609A	Terminal, Battery	1
17	56037A	Motor (24V) 3400 RPM (590 B)	1
18	41602A	Connector, Housing	1
19	41601A	Connector, contact	1

Clarke®
Model 590/590B
Wiring Diagram 12/98

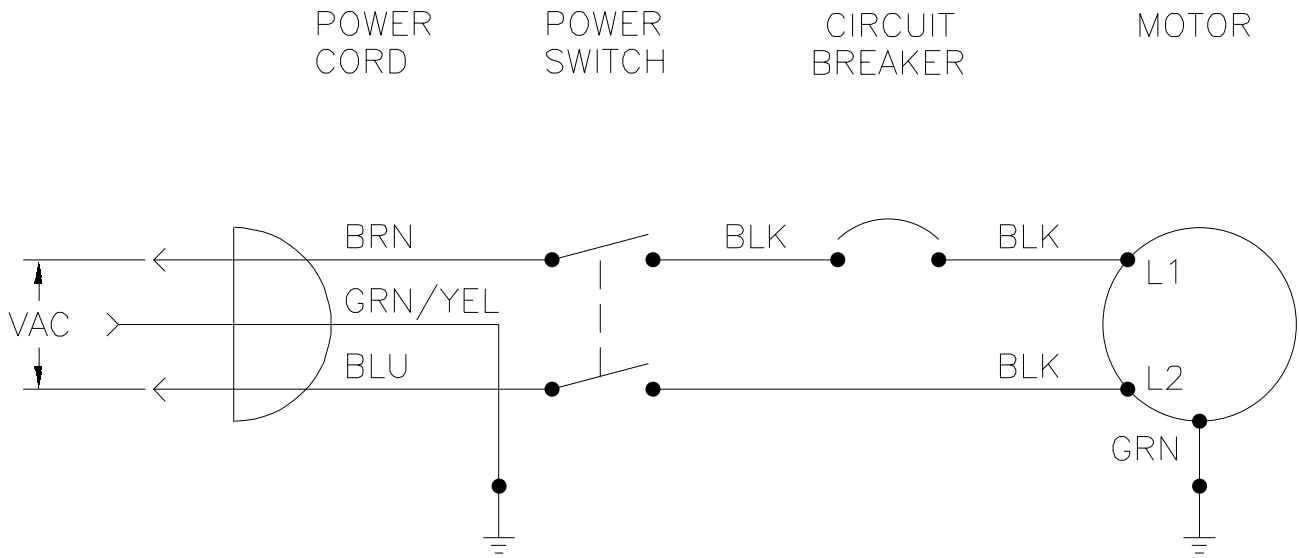

NOTE: FOR USE WITH PART NUMBER 615427.

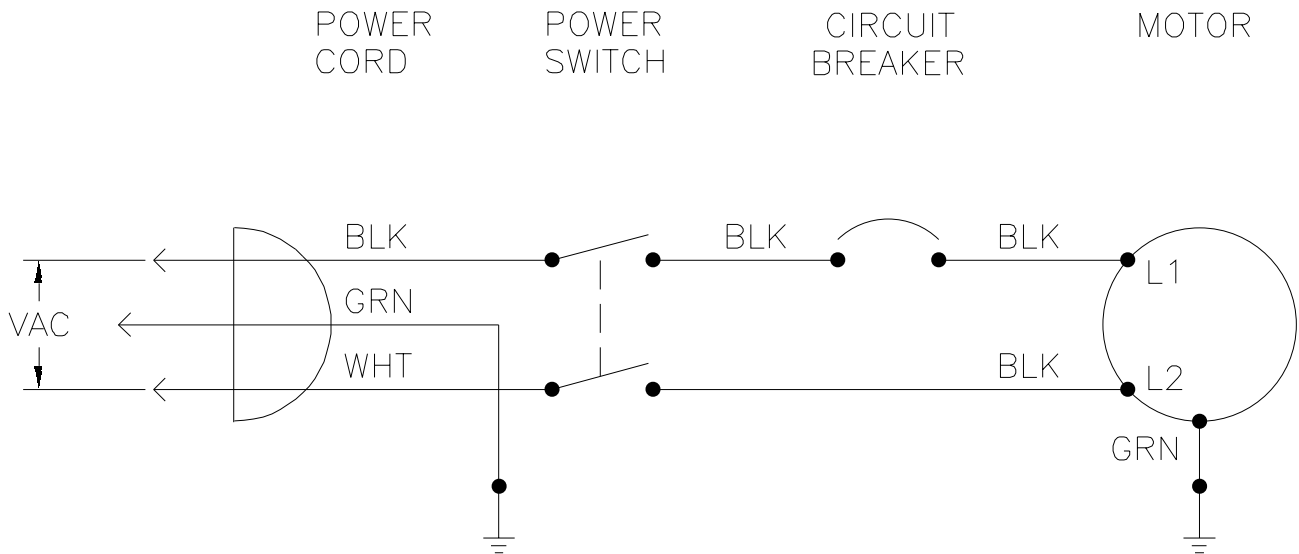

NOTE: FOR USE WITH PART NUMBER 615421.

**Clarke®
Model 590B
Electrical Schematic 4/94
24 Volts DC**

PRODUCT SUPPORT BRANCHES

U. S. A. Locations

HEAD OFFICE

ALTO U.S. Inc., St. Louis, Missouri
16253 Swingley Ridge Road, Suite 200
Chesterfield, Missouri 63017-1725

PRODUCTION FACILITIES

Clarke®, Springdale, Arkansas
2100 Highway 265
Springdale, Arkansas 72764
(479) 750-1000
Customer Service - 1-800-253-0367
Technical Service - 1-800-356-7274

American Lincoln®, Bowling Green, Ohio 43402
1100 Haskins Road

SERVICE FACILITIES

Clarke®, Carlstadt, New Jersey 07072
150 Commerce Road
(201) 460-4774

Clarke®, Elk Grove, Illinois 60007
2280 Elmhurst Road
(847) 956-7900

Clarke®, Denver, Colorado 80204
1955 West 13th Ave.
(303) 623-4367

Clarke®, Houston, Texas 77040
7215 North Gessner Road

SALES AND SERVICE FACILITIES

American Lincoln® / Clarke®, Madison Heights,
Michigan 48071-0158
29815 John R.
(810) 544-6300

American Lincoln® / Clarke®, Marietta, Georgia 30062
1355 West Oak Common Lane
(770) 973-5225

Clarke®
Clarke American Sanders
A.L. Cook
Customer Service Headquarters and Factory
2100 Highway 265
Springdale, Arkansas 72764
(479) 750-1000

Technical Service
1-800-356-7274

European Locations

PRODUCTION FACILITIES

ALTO Danmark A/S, Aalborg
Blytaekkervej 2
DK-9000 Aalborg
+45 72 18 21 00

ALTO Danmark A/S, Hadsund
Industrivarveret
DK-9560 Hadsund
+45 72 18 21 00

SALES SUBSIDIARIES

Clarke® Canada Ltd., Rexdale Ontario
24 Constellation Ct.
(416) 675-5830

ALTO Overseas Inc., Sydney (Australia)
1B/8 Resolution Drive
Caringbah NSW 2229
+61 2 9524 6122

ALTO Cleaning Systems Asia Pte Ltd., Singapore
No. 17 Link Road
Singapore 619034
+65 268 1006

ALTO Deutschland GmbH, Bellenberg (Germany)
Guido-Oberdorfer-Straße 2-8
89287 Bellenberg
+49 0180 5 37 37 37

ALTO Cleaning Systems (UK) Ltd., Penrith
Gilwilly Industrial Estate
Penrith
Cumbria CA11 9BN
+44 1768 868 995

ALTO France S.A. Strasbourg
B.P. 44, 4 Place d'Ostwald
F-67036 Strasbourg
Cedex 2
+33 3 8828 8400

ALTO Nederland B.V. Vianen
Stuartweg 4C
NL-4131 NJ Vianen
+31 347 324000

ALTO Sverige AB, Molndal (Sweden)
Aminogatan 18
Box 4029
S-431 04 Molndal
+46 31 706 73 00

ALTO Norge A/S, Oslo (Norway)
Bjornerudveien 24
N-1266
+47 2275 1770

Clarke® U.S. WARRANTY

This Clarke Industrial/Commercial Product is warranted to be free from defects in materials and workmanship under normal use and service for a period of one year from the date of purchase, when operated and maintained in accordance with Clarke's Maintenance and Operations instructions.

This warranty is extended only to the original purchaser for use of the product. It does not cover normal wear parts such as electrical cable, rubber parts, hoses and motor brushes.

If difficulty develops with the product, you should:

- (a). Contact the nearest authorized Clarke repair location or contact the Clarke Service Operations Department, 2100 Highway 265, Springdale, Arkansas 72764, for the nearest authorized Clarke repair location. Only these locations are authorized to make repairs to the product under this warranty.
- (b). Return the product to the nearest Clarke repair location. Transportation charges to and from the repair location must be prepaid by the purchaser.
- (c). Clarke will repair the product and/ or replace any defective parts without charge within a reasonable time after receipt of the product.

Clarke's liability under this warranty is limited to repair of the product and/or replacement of parts and is given to purchaser in lieu of all other remedies, including INCIDENTAL AND CONSEQUENTIAL DAMAGES.

THERE ARE NO EXPRESS WARRANTIES OTHER THAN THOSE SPECIFIED HEREIN. THERE ARE NO WARRANTIES WHICH EXTEND BEYOND THE DESCRIPTION OF THE FACE HEREOF. NO WARRANTIES, INCLUDING BUT NOT LIMITED TO WARRANTY OF MERCHANTABILITY, SHALL BE IMPLIED. A warranty registration card is provided with your Clarke product. Return the card to assist Clarke in providing the performance you expect from your new floor machine.

Clarke®, 2100 Highway 265, Springdale, Arkansas 72764.

Clarke® reserves the right to make changes or improvements to its machine without notice.

Always use genuine Clarke® Parts for repair.

Division of

**2100 Highway 265
Springdale, Arkansas, 72764**